

PARTS LIST

CHAIN SAW

G3300
G3300EZ
G3300E

NOTE :

1. Use ZENOAH genuine parts specified in the parts list for repair and/or replacement.
2. ZENOAH does not warrant the machines, those which have been damaged by the use of any parts other than those specified by the company.
3. When placing orders of parts for repair and/or replacement, check if the model name and the serial number are suitable to those specified in the parts list, then use parts number described in the parts list.
4. The contents described in the parts list may change due to improvement.
5. The parts for the machine shall be supplied within ten (10) years after the machine is discontinued. [It is possible that some specific parts may be subject to change of their delivery term and list price within the limit of ten (10) years after the machine is discontinued. And it is also possible that some parts may be available even after the limit of ten (10) years.]

Fig.1 POWER UNIT

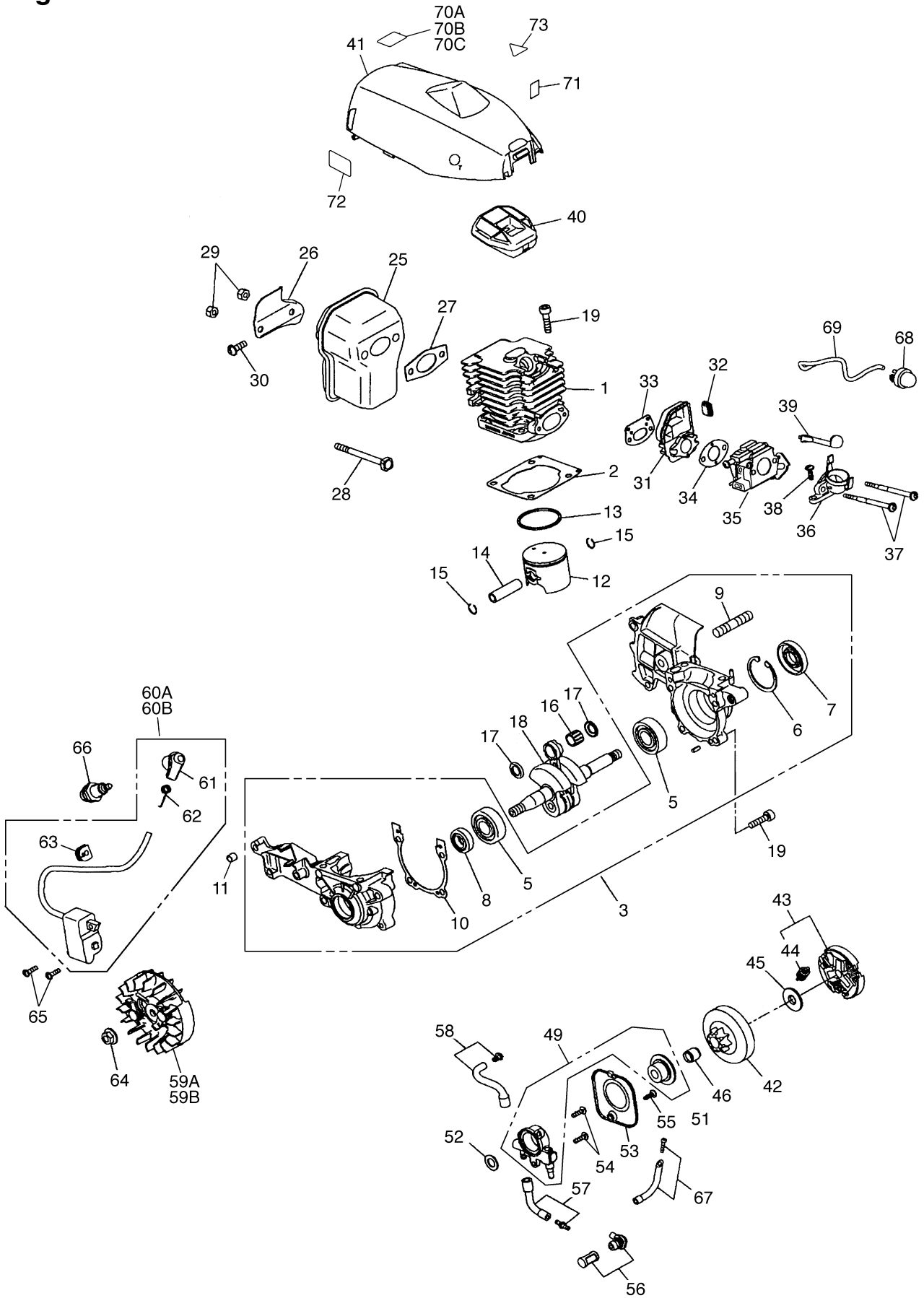

Fig.1 POWER UNIT

Key#	PART NUMBER	DESCRIPTION	Q'TY /UNIT	NOTE	Key#	PART NUMBER	DESCRIPTION	Q'TY /UNIT	NOTE
1	848C3012A1	CYLINDER	1		58	T2200-21400	PIPE OUT COMP.	1	
2	T2200-14210	GASKET, cyl	1	*	59A	848C357111	ROTOR COMP.	1	G3300
3	848C302102	CASE ASSY	1		59B	848C307111	ROTOR COMP.	1	G3300EZ G3300E
5	06030-06201	• BEARING	2		60A	848C357121	COIL ASSY	1	G3300
6	04065-03212	• SNAPRING ϕ 32	1		60B	848C307121	COIL ASSY	1	G3300EZ G3300E
7	2169-21210	• SEAL	1		61	2850-72110	• CAP	1	
8	8488AC3210	• SEAL	1		62	1400-72121	• SPRING	1	
9	2616-21230	• STUD	1		63	5500-72130	• GROMMET	1	
10	848C3021D1	• GASKET	1	*	64	1650-43230	NUT M8xP1.0	1	
11	8488Y56000	SPACER	1		65	2670-55410	SCREW M4xL14 T20	2	
12	T2200-41110	PISTON	1		66	3699-90032-10	SPARK PLUG	1	BPMR7A
13	T2102-41210	RING	1		67	T2100-31500	PIPE COMP.	1	
14	T2200-41310	PIN	1		68	2850-81900	PUMP	1	
15	3310-41320	RING	2		69	2850-82611	PIPE	1	
16	3310-41410	BEARING	1		70A	848C3590F0	LABEL, caution	1	G3300
17	1650-41510	WASHER	2		70B	848C3690F0	LABEL, caution	1	G3300EZ
18	T2200-42000	SHAFT COMP.	1		70C	848C3F90F0	LABEL, caution	1	G3300E
19	4820-13180	BOLT TORX M5xL20 T27	8		71	848C3090E0	LABEL, choke	1	
25	T2200-15110	MUFFLER	1		72	T2990-21120	LABEL	1	
26	T2200-15310	STAY	1		73	848C1B90G0	LABEL, hot mark	1	G3300E
27	T2100-15210	GASKET	1	*		848C300610	GASKET KIT (*: #2,10,27,33,34)	1	OPTION
28	T2100-15220	BOLT	2						
29	2850-15230	NUT	2						
30	8488151400	SCREW M5xL14 T27	1						
31	848C3014A1	INSULATOR	1						
32	T2200-31120	CAP	1						
33	848C3014B1	GASKET, in	1	*					
34	3330-14121	GASKET,carb	1	*					
35	848C3A8100	CARBURETOR ASSY	1	WT748					
36	848C3082A2	MANIFOLD	1						
37	2867-82210	BOLT M4x70	2						
38	8488251601	SCREW TP5(P-tight)xL16 T27	1						
39	848C3082F2	ROD CHOKE	1						
40	T2200-83100	CLEANER	1						
41	848C3031A2	COVER	1						
42	T2220-51110	DRUM 3/8x6T ϕ 60	1						
43	848C305121	CLUTCH	1						
44	848C3051E2	• SPRING	3						
45	T2041-51210	PLATE	1						
46	3310-51310	BEARING	1						
49	848CA00640	OIL PUMP SET • OIL PUMP • WORM	1 1 1						
52	2850-55211	WASHER	1						
53	T2200-55610	COVER	1						
54	2670-55410	SCREW M4xL14 T20	2						
55	2670-54630	SCREW TP4(B-tight)xL12 T20	1						
56	T2100-23200	FILTER COMP.	1						
57	848C306732	PIPE IN COMP.	1						

Fig.2 POWER UNIT

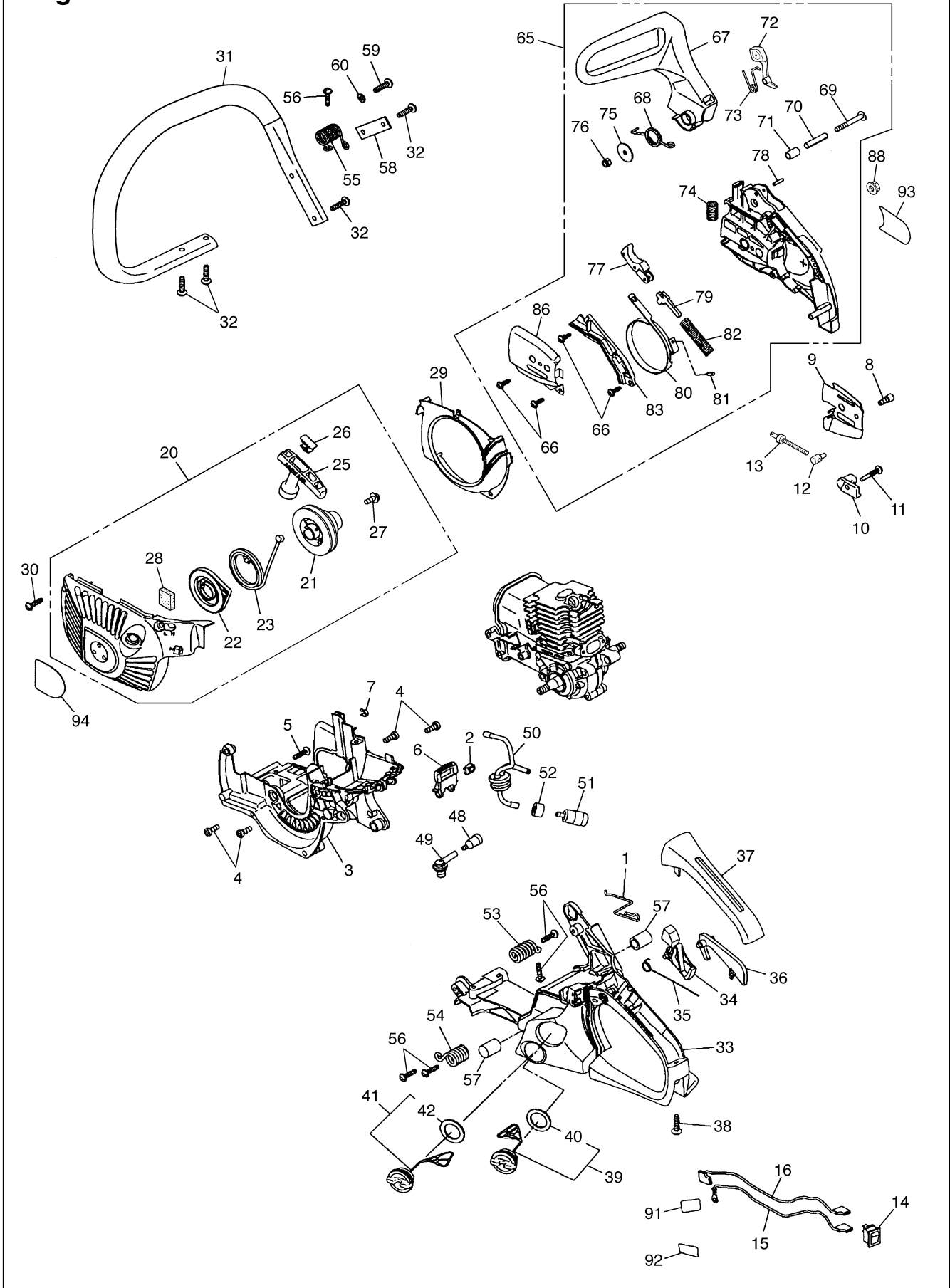

Fig.2 POWER UNIT

Key#	PART NUMBER	DESCRIPTION	Q'TY /UNIT	NOTE	Key#	PART NUMBER	DESCRIPTION	Q'TY /UNIT	NOTE
1	848C3082H3	ROD	1		59	8488251601	SCREW TP5(P-tight)xL16 T27	1	
2	848C3082G2	GROMMET	1		60	01640-20508	WASHER	1	
3	848C3025A2	CASE	1						
4	8488151400	SCREW M5xL14 T27	4		65	848C355403	BRAKE ASSY	1	
5	8488251911	SCREW TP5(P-tight)xL19 T27	1		66	2670-54630	• SCREW TP4(B-tight)xL12 T20	4	
6	848C3025C2	KNOB	1						
7	848C3025D0	CLIP	1		67	848C3054A2	• GUARD	1	
8	T2200-21230	BOLT	1		68	2850-54120	• SPRING	1	
9	848C306612	PLATE	1		69	2850-54130	• SCREW	1	
10	848C3066F2	CATCHER	1		70	2850-54140	• SPACER	1	
11	8488251911	SCREW TP5(P-tight)xL19 T27	1		71	2850-54211	• SPACER	1	
12	3310-53320	NUT	1		72	848C605423	• WEIGHT	1	
13	8488353900	SCREW	1		73	2872-54230	• SPRING	1	
14	2850-74102	SWITCH ASSY	1		74	2851-54270	• SPRING	1	
15	848C3072C1	CORD EARTH	1		75	3330-75411	• WASHER	1	
16	848C3072B1	CORD SWITCH	1		76	3310-53331	• NUT	1	
					77	2851-54301	• LEVER COMP.	1	
20	848C357502	STARTER ASSY	1		78	2851-54350	• ROLLER	1	
21	848C3575C1	• REEL	1		79	2670-54411	• ARM	1	
22	2841-75300	• SPRING COMP.	1		80	T2200-54510	• BAND	1	
23	T2044-75410	• ROPE ø3	1		81	3356-24140	• ROLLER	1	
					82	2670-54610	• SPRING	1	
25	1400-75170	• KNOB	1		83	848C3053C2	• COVER	1	
26	T2044-75420	• KNOB CAP	1						
27	T1812-75150	• SCREW M5xL12	1		86	848C3066C1	• PLATE(B)	1	
28	848C3074B0	• CUSHION	1						
29	848C3074A1	COVER	1		88	3350-53410	NUT	1	
30	8488251911	SCREW TP5(P-tight)xL19 T27	3						
31	848C3332A1	HANDLE	1		91	848C3090K0	LABEL	1	
32	8488252711	SCREW TP5(P-tight)xL27 T27	4		92	848C3090L0	LABEL	1	
33	848C303311	HANDLE COMP.	1		93	848C3590B1	LABEL, cover	1	
34	848C3033C1	LEVER	1						
35	3356-33321	SPRING	1		94	848C3590C1	LABEL, case	1	
36	848C3033E3	ARM	1						
37	848C3033L1	COVER	1						
38	8488251911	SCREW TP5(P-tight)xL19 T27	1						
39	848C108512	CAP ASSY	1						
40	2841-31820	• GASKET	1						
41	848C208511	CAP ASSY	1						
42	2841-31820	• GASKET	1						
48	2850-34501	BREATHER ASSY	1						
49	848C3085U0	GROMMET	1						
50	848C308530	PIPE ASSY	1						
51	1850-85300	FILTER	1						
52	2850-34350	COLLAR	1						
53	848C3037A1	SPRING F	1						
54	848C3037B1	SPRING M	1						
55	848C3037C1	SPRING P	1						
56	8488251901	SCREW TP5(P-tight)xL19 T27	5						
57	848C3037D2	HELPER	2						
58	848C3037E1	BAND	1						

Fig.3 POWER UNIT

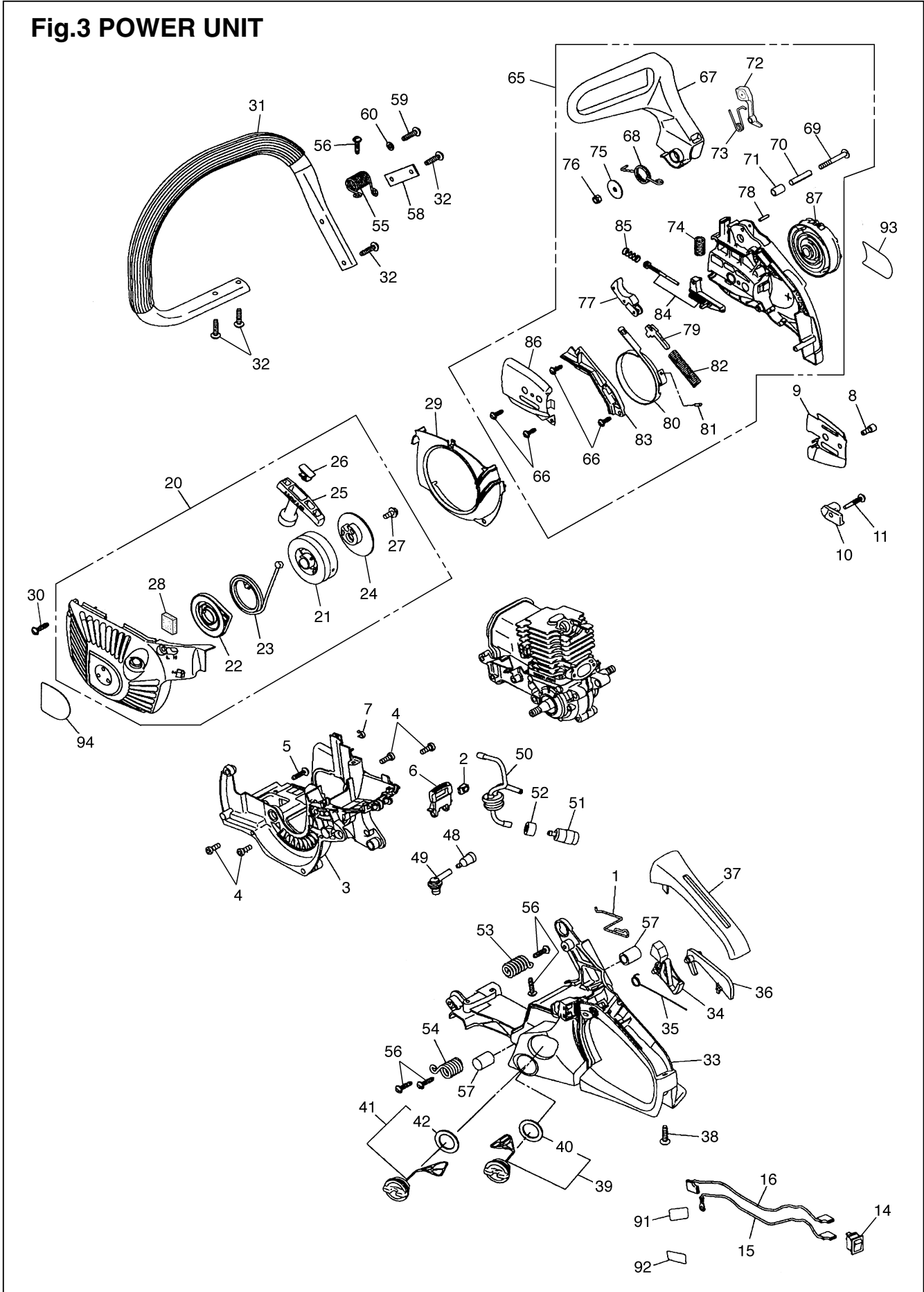

Fig.3 POWER UNIT

Key#	PART NUMBER	DESCRIPTION	Q'TY /UNIT	NOTE	Key#	PART NUMBER	DESCRIPTION	Q'TY /UNIT	NOTE
1	848C3082H3	ROD	1		60	01640-20508	WASHER	1	
2	848C3082G2	GROMMET	1						
3	848C3025A2	CASE	1		65	848C365401	BRAKE ASSY	1	
4	8488151400	SCREW M5xL14 T27	4		66	2670-54630	• SCREW TP4(B-tight)xL12 T20	3	
5	8488251911	SCREW TP5(P-tight)xL19 T27	1		67	848C3054A2	• GUARD	1	
6	848C3025C2	KNOB	1		68	2850-54120	• SPRING	1	
7	848C3025D0	CLIP	1		69	2850-54130	• SCREW	1	
8	T2200-21230	BOLT	1		70	2850-54140	• SPACER	1	
9	848C306612	PLATE	1		71	2850-54211	• SPACER	1	
10	848C3066F2	CATCHER	1		72	848C605423	• WEIGHT	1	
11	8488251911	SCREW TP5(P-tight)xL19 T27	1		73	2872-54230	• SPRING	1	
					74	2851-54270	• SPRING	1	
14	2850-74102	SWITCH ASSY	1		75	3330-75411	• WASHER	1	
15	848C3072C1	CORD EARTH	1		76	3310-53331	• NUT	1	
16	848C3072B1	CORD SWITCH	1		77	2851-54301	• LEVER COMP.	1	
					78	2851-54350	• ROLLER	1	
20	848C307502	STARTER ASSY	1		79	2670-54411	• ARM	1	
21	848C307520	• REEL COMP.	1		80	T2200-54510	• BAND	1	
22	2841-75300	• SPRING COMP.	1		81	3356-24140	• ROLLER	1	
23	T2044-75410	• ROPE ø3	1		82	2670-54610	• SPRING	1	
24	T2044-75510	• PULLEY	1		83	848C3053C2	• COVER	1	
25	1400-75170	• KNOB	1		84	T2200-53200	• LINK A	1	
26	T2044-75420	• KNOB CAP	1		85	T2200-53280	• SPRING	1	
27	T1812-75150	• SCREW M5xL12	1		86	848C3066C1	• PLATE(B)	1	
28	848C3074B0	• CUSHION	1		87	848C305341	• NUT ASSY	1	
29	848C3074A1	COVER	1						
30	8488251911	SCREW TP5(P-tight)xL19 T27	3		91	848C3090K0	LABEL	1	
31	T2200-32100	HANDLE	1		92	848C3090L0	LABEL	1	
32	8488251901	SCREW TP5(P-tight)xL19 T27	4		93	848C3090B1	LABEL, cover	1	
33	848C303311	HANDLE COMP.	1		94	848C3690C1	LABEL, case	1	
34	848C3033C1	LEVER	1						
35	3356-33321	SPRING	1						
36	848C3033E3	ARM	1						
37	848C3033L1	COVER	1						
38	8488251911	SCREW TP5(P-tight)xL19 T27	1						
39	848C108512	CAP ASSY	1						
40	2841-31820	• GASKET	1						
41	848C208511	CAP ASSY	1						
42	2841-31820	• GASKET	1						
48	2850-34501	BREATHER ASSY	1						
49	848C3085U0	GROMMET	1						
50	848C308530	PIPE ASSY	1						
51	1850-85300	FILTER	1						
52	2850-34350	COLLAR	1						
53	848C3037A1	SPRING F	1						
54	848C3037B1	SPRING M	1						
55	848C3037C1	SPRING P	1						
56	8488251901	SCREW TP5(P-tight)xL19 T27	5						
57	848C3037D2	HELPER	2						
58	848C3037E1	BAND	1						
59	8488251601	SCREW TP5(P-tight)xL16 T27	1						

Fig.4 POWER UNIT

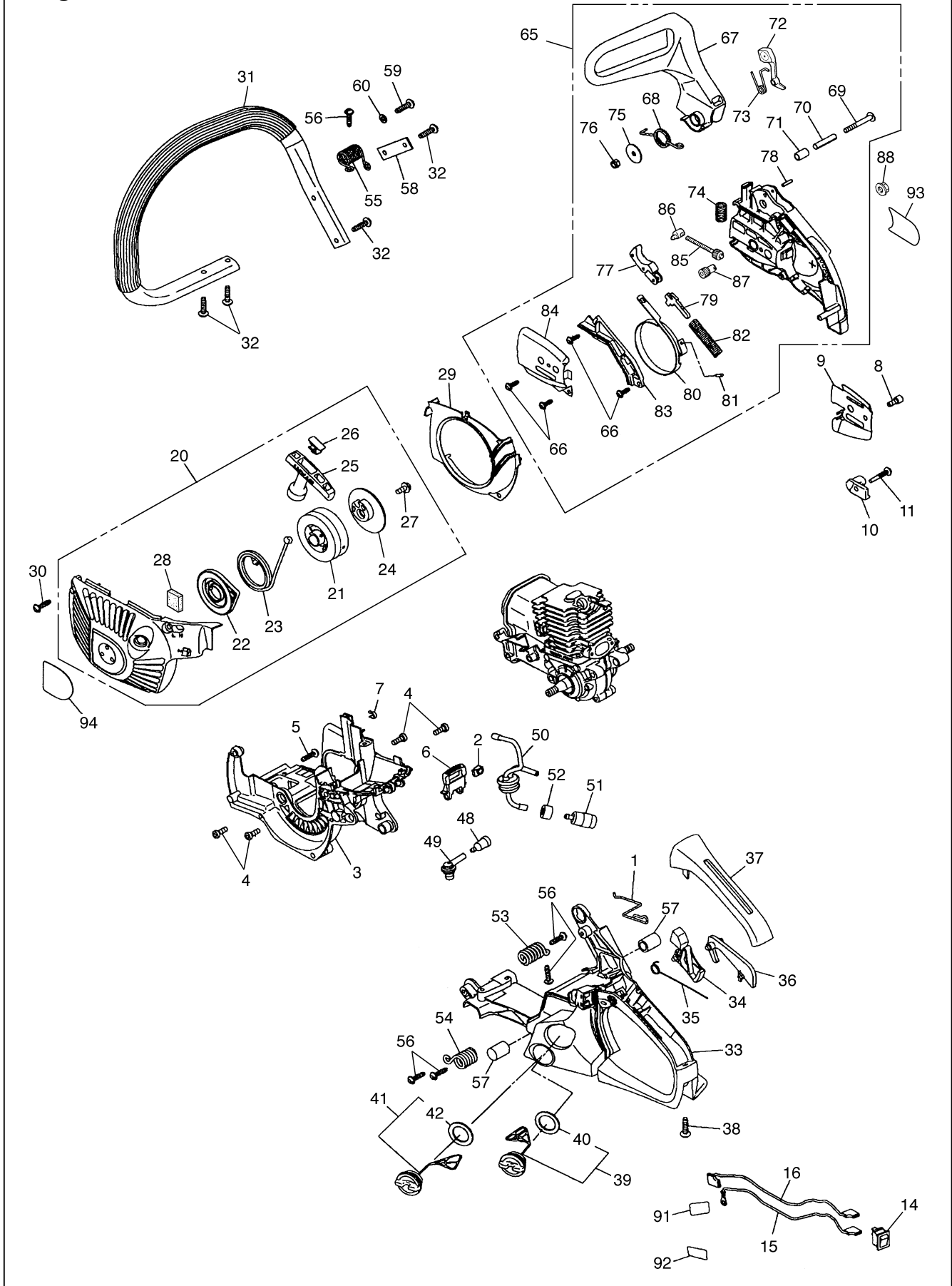
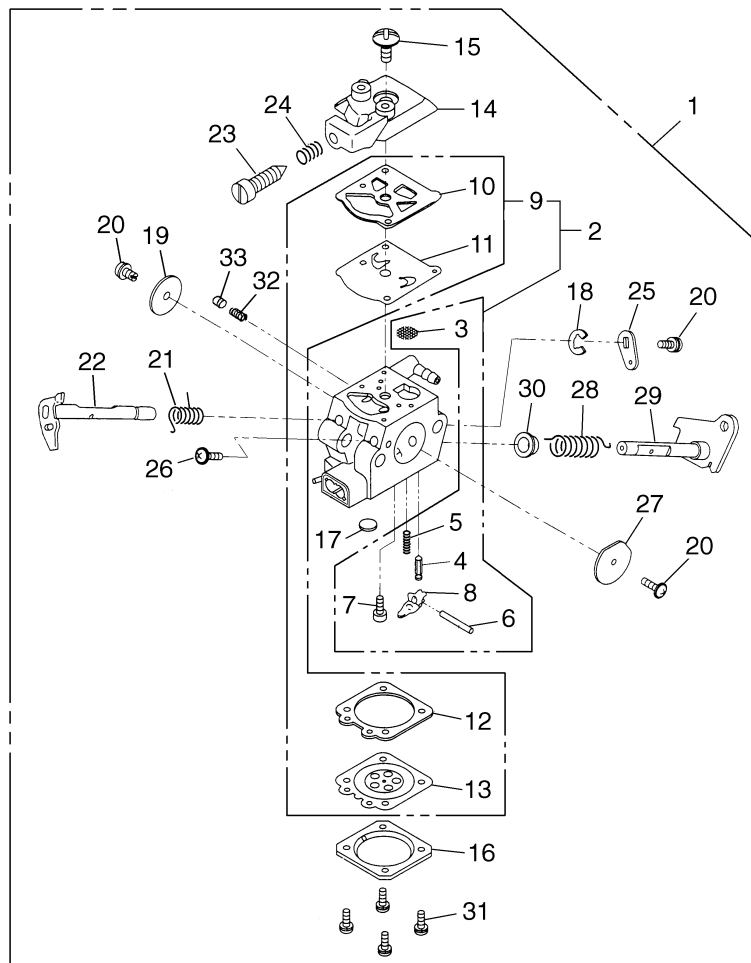

Fig.4 POWER UNIT

Key#	PART NUMBER	DESCRIPTION	Q'TY /UNIT	NOTE	Key#	PART NUMBER	DESCRIPTION	Q'TY /UNIT	NOTE
1	848C3082H3	ROD	1		60	01640-20508	WASHER	1	
2	848C3082G2	GROMMET	1						
3	848C3025A2	CASE	1		65	848C3A5401	BREAK ASSY	1	
4	8488151400	SCREW M5xL14 T27	4		66	2670-54630	• SCREW TP4(B-tight)xL12 T20	4	
5	8488251911	SCREW TP5(P-tight)xL19 T27	1		67	848C3054A2	• GUARD	1	
6	848C3025C2	KNOB	1		68	2850-54120	• SPRING	1	
7	848C3025D0	CLIP	1		69	2850-54130	• SCREW	1	
8	T2200-21230	BOLT	1		70	2850-54140	• SPACER	1	
9	848C306612	PLATE	1		71	2850-54211	• SPACER	1	
10	848C3066F2	CATCHER	1		72	848C605423	• WEIGHT	1	
11	8488251911	SCREW TP5(P-tight)xL19 T27	1		73	2872-54230	• SPRING	1	
					74	2851-54270	• SPRING	1	
14	2850-74102	SWITCH ASSY	1		75	3330-75411	• WASHER	1	
15	848C3072C1	CORD EARTH	1		76	3310-53331	• NUT	1	
16	848C3072B1	CORD SWITCH	1		77	2851-54301	• LEVER COMP.	1	
					78	2851-54350	• ROLLER	1	
20	848C307502	STARTER ASSY	1		79	2670-54411	• ARM	1	
21	848C307520	• REEL COMP.	1		80	T2200-54510	• BAND	1	
22	2841-75300	• SPRING COMP.	1		81	3356-24140	• ROLLER	1	
23	T2044-75410	• ROPE ø3	1		82	2670-54610	• SPRING	1	
24	T2044-75510	• PULLEY	1		83	848C3053C2	• COVER	1	
25	1400-75170	• KNOB	1		84	848C3066C1	• PLATE(B)	1	
26	T2044-75420	• KNOB CAP	1		85	2841-53240	• SCREW	1	
27	T1812-75150	• SCREW M5xL12	1		86	848C3366K0	• NUT	1	
28	848C3074B0	• CUSHION	1		87	2671-53230	• GEAR	1	
29	848C3074A1	COVER	1		88	3350-53410	NUT	1	
30	8488251911	SCREW TP5(P-tight)xL19 T27	3						
31	T2200-32100	HANDLE	1		91	848C3090K0	LABEL	1	
32	8488251901	SCREW TP5(P-tight)xL19 T27	4		92	848C3090L0	LABEL	1	
33	848C303311	HANDLE COMP.	1		93	848C3590B1	LABEL, cover	1	
34	848C3033C1	LEVER	1		94	848C3F90C1	LABEL, case	1	
35	3356-33321	SPRING	1						
36	848C3033E3	ARM	1						
37	848C3033L1	COVER	1						
38	8488251911	SCREW TP5(P-tight)xL19 T27	1						
39	848C108512	CAP ASSY	1						
40	2841-31820	• GASKET	1						
41	848C2085G1	CAP ASSY	1						
42	2841-31820	• GASKET	1						
48	2850-34501	BREATHER ASSY	1						
49	848C3085U0	GROMMET	1						
50	848C308530	PIPE ASSY	1						
51	1850-85300	FILTER	1						
52	2850-34350	COLLAR	1						
53	848C3037A1	SPRING F	1						
54	848C3037B1	SPRING M	1						
55	848C3037C1	SPRING P	1						
56	8488251901	SCREW TP5(P-tight)xL19 T27	5						
57	848C3037D2	HELPER	2						
58	848C3037E1	BAND	1						
59	8488251601	SCREW TP5(P-tight)xL16 T27	1						

Fig.5 CARBURETOR COMPONENTS



Key#	PART NUMBER	DESCRIPTION	Q'TY /UNIT	NOTE	Key#	PART NUMBER	DESCRIPTION	Q'TY /UNIT	NOTE
1	848C3A8100	CARBURETOR ASSY	1		19	3310-81341	• VALVE	1	
2	848C3A0630	• REBUILD-KIT	1	(OP)	20	2880-81470	• SCREW	3	
3	3306-81380	•• SCREEN	1		21	2670-81410	• SPRING	1	
4	3356-81310	•• VALVE	1		22	848C3A81T0	• SHAFT	1	
5	2841-81270	•• SPRING	1		23	2630-81330	• SCREW	1	
6	3310-81250	•• PIN	1		24	3350-81380	• SPRING	1	
7	3310-81240	•• SCREW	1		25	2670-81440	• LEVER	1	
8	3310-81230	•• LEVER	1		26	2850-81190	• SCREW	1	
9	T2100-06020	•• GASKET KIT	1	(OP)	27	2841-81450	• VALVE	1	
10	3304-81140	••• GASKET	1		28	T2002-81350	• SPRING	1	
11	1172-81150	••• DIAPHRAGM	1		29	848C3081E0	• SHAFT	1	
12	2850-81290	••• GASKET	1		30	2850-81430	• BUSHING	1	
13	3310-81260	••• DIAPHRAGM	1		31	3310-81351	• SCREW	4	
14	2850-81120	• COVER	1		32	2810-81530	• SPRING	1	
15	3310-81130	• SCREW	1		33	848C7180N0	• PISTON	1	
16	3310-81280	• COVER	1						
17	1480-81420	• PLUG	1						
18	1148-81390	• RING	1						

Fig.6 ACCESSORIES

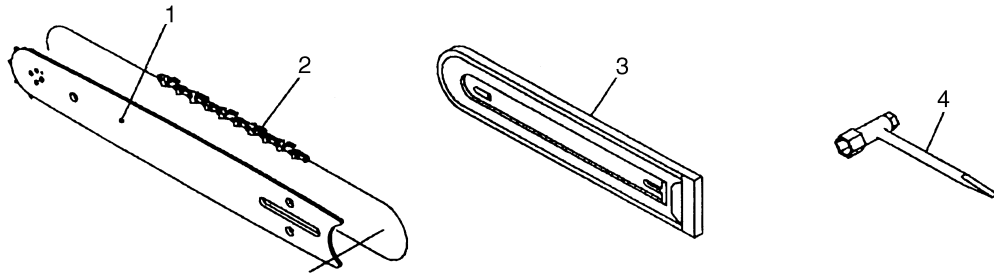

OPTION

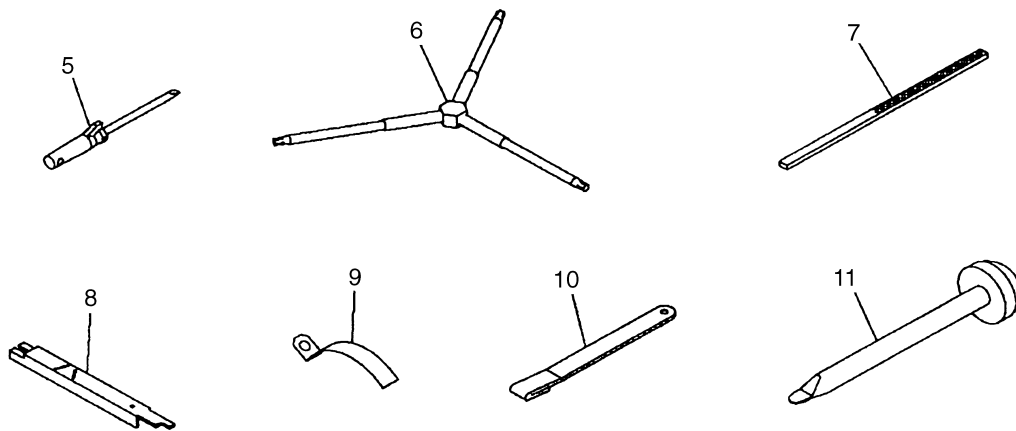

Key#	PART NUMBER	DESCRIPTION	Q'TY /UNIT	NOTE
1	848CB24G23	BAR 35-3/8	1	
2	848CC91S52	CHAIN OREGON 91VX-52E	1	
3	3617-97110	PROTECTOR 300~350mm	1	
4	3320-91140	WRENCH	1	
5	2670-91150	DRIVER	1	OPTION
6	2850-96410	WRENCH	1	OPTION
7	3317-91210	FILE	1	OPTION
8	3310-91540	GAUGE	1	OPTION
9	3330-97310	GAUGE	1	OPTION
10	2670-96220	STOPPER	1	OPTION
11	2670-96510	GUIDE	1	OPTION